

### Features

- Transformerless 2-4 wire conversion
- Line state detection outputs
  - - forward current
  - - reverse current
  - - ring ground
  - - tip ground
  - - ringing voltage
- Programmable audio transmit and receive gain
- Loop start or ground start termination
- Selectable 600Ω or AT&T compromise balance network
- -1 version: 20Hz Ringing Voltage
- -2 version: 50Hz Ringing Voltage

### Applications

- PBX
- Channel bank
- Intercom
- Key System

ISSUE 4

April 1995

#### Ordering Information

MH88631-1 40 Pin SIL Package  
 MH88631-2 40 Pin SIL Package

**0°C to 70°C**

### Description

The Mitel MH88631-1, 2 Central Office Trunk Interface circuit provides a complete audio and signalling link between audio switching equipment and a central office. The loop seize circuitry is controlled by an external input to provide either a loop start or ground start termination. The device is fabricated using thick film ceramic technology to achieve high density circuit design.

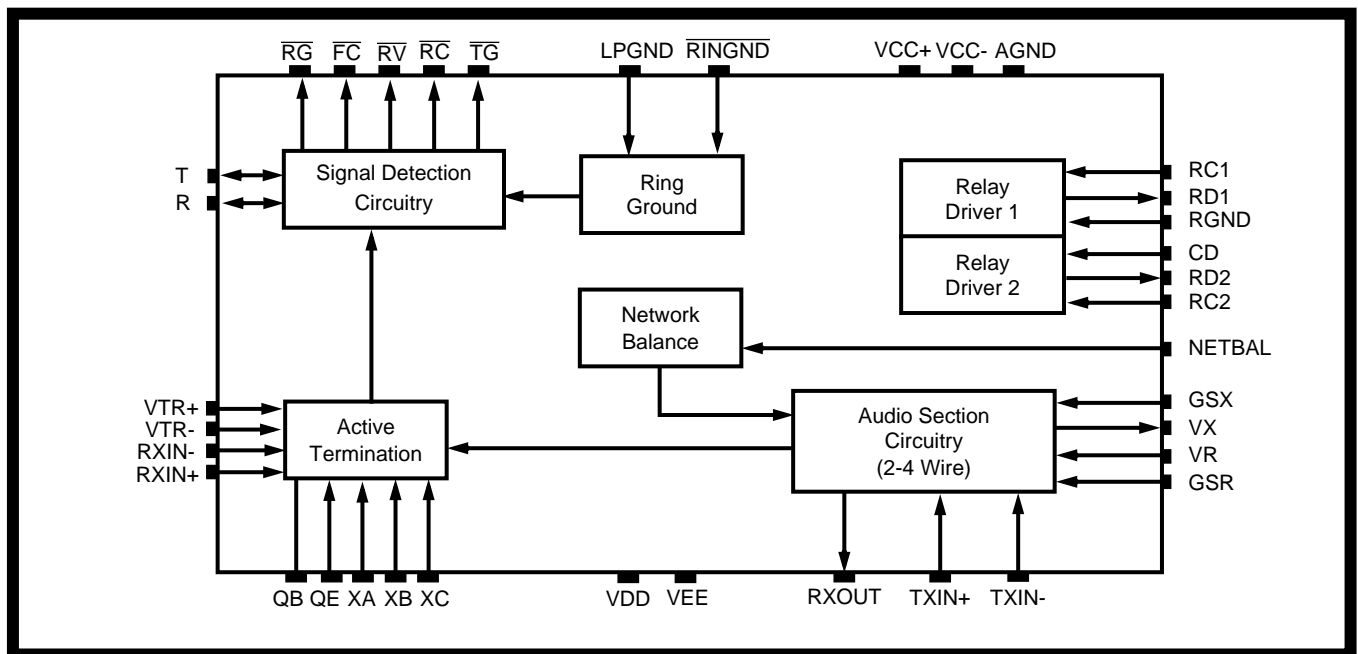

**Figure 1 - Functional Block Diagram**

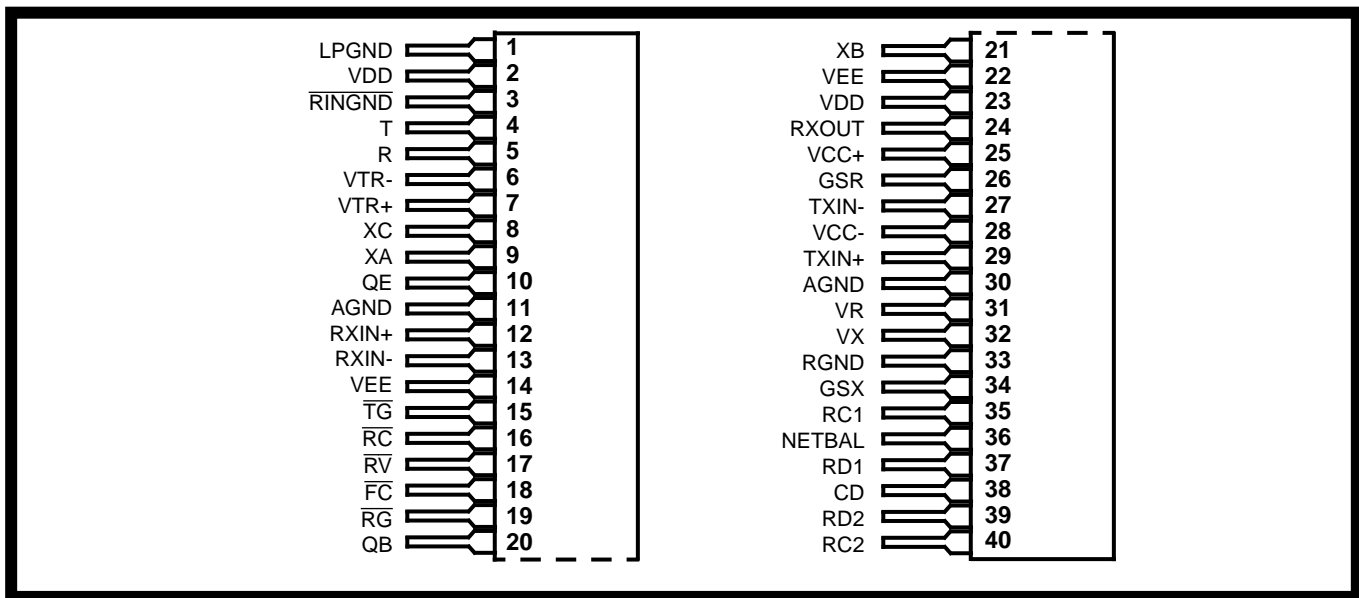

Figure 2 - Pin Connections

## Pin Description

Pin #	Name	Description
1	LPGND	<b>Loop Ground</b> is the system ground reference with respect to -48V.
2	VDD	<b>Positive Power Supply</b> (+5V).
3	RINGND	<b>Ring Ground (Input)</b> . For Ground Start Trunk only a logic low input will enable the trunk circuit to ground the Ring lead through a low resistance (390Ω). This is a signal to the C.O. that the interface is seizing the line.
4	T	<b>Tip (Input)</b> . Normally connects to the “Tip” lead of the C.O.
5	R	<b>Ring (Input)</b> . Normally connects to the “Ring” lead of the C.O.
6	VTR-	Connects to the TXIN+ (Pin 29) via an external capacitor (C1).
7	VTR+	Connects to the collector of an external transistor (Q1) and TXIN- (Pin 27) via an external capacitor (C4)
8	XC	External relay contact (K1) connection from XB (Pin 21), activates by loop seize control input (RC1).
9	XA	External relay contact (K1) connection from VTR+ (Pin 7), activated by loop seize control input (RC1).
10	QE	Connects to the emitter of an external transistor (Q1).
11	AGND	<b>Analog Ground</b> .
12	RXIN+	<b>Differential Receive (Input)</b> . Connects to analog ground via an external capacitor (C2).
13	RXIN-	<b>Differential Receive (Input)</b> . Connects to RXOUT (Pin 24) via an external capacitor (C3).
14	VEE	<b>Negative Power Supply</b> . (-5V).
15	TG	<b>Tip Lead Ground Detect (Output)</b> . Active low.
16	RC	<b>Reverse Loop Current Detect (Output)</b> . Active low.
17	RV	<b>Ringing Voltage Detect (Output)</b> . Active low.
18	FC	<b>Forward Loop Current Detect (Output)</b> . Active low
19	RG	<b>Ring Lead detect (Output)</b> . Active low.
20	QB	Connects to the base of an external transistor (Q1).

## Pin Description (Continued)

Pin #	Name	Description
21	XB	External relay contact (K1) connection from XC (Pin 8), activated by loop seize control input (RC1).
22	VEE	<b>Negative Power Supply.</b> (-5V).
23	VDD	<b>Positive Power Supply.</b> (+5V)
24	RXOUT	Audio receive signal (output) to the RXIN- (Pin 13), via an external decoupling capacitor (C3).
25	VCC+	<b>Positive analog Power Supply Voltage.</b> (+12V).
26	GSR	<b>Gain Setting Receive (Input).</b> Normally used to set the receive gain with an external resistor connected to RXOUT (Pin 24).
27	TXIN-	<b>Transmit (Input).</b> Differential audio signal from VTR- (Pin 6), via an external capacitor (C4).
28	VCC-	<b>Negative Analog Power Supply Voltage.</b> (-12V).
29	TXIN+	<b>Transmit (Input).</b> Differential audio signal from VTR- (Pin 6), via an external decoupling capacitor (C1).
30	AGND	<b>Analog Ground.</b>
31	VR	<b>Audio Receive (Input).</b> The four-wire audio signal input to the interface.
32	VX	<b>Audio Transmit (Output).</b> The four-wire audio signal output from the interface.
33	RGND	<b>Relay Ground.</b>
34	GSX	<b>Gain Setting Transmit (Input).</b> Normally used to set the transmit gain with an external resistor connected to VX (Pin 32).
35	RC1	<b>Relay Control 1 (Input).</b> A logic high will activate the relay (K1) to provide loop seize across Tip and Ring.
36	NETBAL	<b>Network Balance (Input).</b> When there is no connection (open), the network is balanced at 600Ω. When the pin is grounded, the network is balanced at AT&T compromise.
37	RD1	<b>Relay Driver 1 (Output).</b> Open collector sinks current when RC1 is high. Diode clamp protected.
38	CD	<b>Clamping Diode.</b> Normally connects to the positive supply voltage.
39	RD2	<b>Relay Driver 2 (Output).</b> Open collector sinks current when RC2 is high. Diode clamp protected.
40	RC2	<b>Relay Driver 2 (Input).</b> A logic high will activate the relay (K2) to provide proper biasing to the Tip and Ring. This input control is used for Ground Start Trunk only.

## Functional Description

The MH88631-1, 2, is a Central Office Loop Start and/or Ground start analog Trunk interface circuit providing a complete audio and signalling link to the Central Office.

The trunk interface circuit performs transformerless 2 to 4 wire conversion, between the 2-wire telephone loop and the 4 wire transmit and receive pairs of a voice switching system. The 4-wire connection can be interfaced to a filter/ codec, such as the MT896X, for use in a digital voice switched system.

Voiceband analog signals, coming for the C.O., applied differentially across Tip and Ring, pass through a bridge rectifier and appear at VTR+ and VTR- where they are actively terminated. Refer to Fig. 3 - Application Circuit. External capacitors C1 and C4 couple the incoming signals into the balanced input of the Transmit audio circuitry via TXIN+ and TXIN-. The transmit gain is adjusted by feedback resistor R4. For best performance R4 should be physically located as close as possible to the GSX pin. The gain adjusted transmit signal appears at the Vx output pin.

Relay K1 is the loop seize which applies active line termination and also provides biasing of the current modulator circuitry. Activating and deactivating K1 provides dial pulsing. Q1 is the current modulator output transistor, referred to as the loop driver transistor.

Outgoing analog signals from the system are provided to the interface at the VR input where they enter an amplifier section with the gain controlled by the selection of the Rx gain feedback resistor R3. For best performance, R3 should be physically located as close as possible to the GSR pin. The output of the amplifier, RXOUT, is coupled to RXIN-, the current modulator circuitry, via C3. The balanced input to the current modulator is completed with the connection of C2 from RXIN+ to ground. Transmission to the C.O. is accomplished by modulating the loop with the outgoing analog signals. To ensure that the transmitted signals are not coupled to the receive circuitry, transhybrid loss is maximised. The impedance matching, performed by the balance network reduces power loss and signal reflections. The network balance input, NETBAL, of the interface's 2-wire to 4-wire convertor circuitry provides selection of a 600Ω balance, used when feeding channel banks or when performing external tests on the trunk circuit, or the AT&T compromise. When the NETBAL input pin is grounded, the interface balance against the AT&T

compromise network consisting of 350Ω plus 1kΩ shunted by a 0.21μF capacitor. This is typical of North American C.O. connections.

The Tip and Ring also provide the balanced input to the signal detection circuitry which generates the signalling status outputs  $\overline{TG}$ ,  $\overline{RC}$ ,  $\overline{RV}$ ,  $\overline{FC}$  and  $\overline{RG}$ .

For Ground Start signalling, relay K2 and resistor R1 and R2, are required. Activation of K2 is controlled by the relay control logic input signal, RC2. In the idle state, K2 is closed connecting the -48 VDC supply Tip and Ring through biasing resistors R1 and R2. Upon detection of  $\overline{TG}$  or  $\overline{RG}$ , the system then pulls RC1 low, closing K1, then pulls RC2 low which opens K2 to remove the -48 volts supply from Tip and Ring.

In the Ground Start signalling environment, initiating a call to the C.O. is performed by the following sequence of events. The system provides a logic low on the ring ground input pin of the interface. This activates the circuitry which grounds the ring lead through a current limiting resistance. The C.O. recognizes the ground condition and connects the tip lead to ground. The interface senses this condition and the tip lead ground detect output switches to a logic low. The system then applies active line termination by closing K1 using RC1 and opens K2 using RC2. A call from the C.O. can be performed similarly. The C.O. can signal to the interface by pulling either Tip or Ring to ground potential, or by applying ringing voltage to the Ring lead.

## Signal Detection Circuitry

The signal detection circuitry provides the signalling status outputs. The system, controlling the interfaces, monitors these active low logic outputs.  $\overline{RV}$  is the Ringing Voltage detect outputs. When the C.O. applies ringing voltage to the termination, the trunk interface provides a 50ms debounced output at RV during the ringing burst period. This output will remain low for approximately 50ms after C.O. removes the ringing Voltage. Ringing voltage above 40 VRMS at 20Hz will be detected.

$\overline{TG}$  is the Tip lead Ground detect output and  $\overline{RG}$  is the Ring lead Ground detect output. The  $\overline{TG}$  and  $\overline{RG}$  outputs provides a means of determining call original or other hand shaking functions. The high impedance detection circuitry of the interface will detect both Tip and Ring Ground voltages above approximately -15.3V of true ground.

RC is the Reverse Loop Current detect output and FC is the Forward Loop Current detect output.

The RC and  $\overline{FC}$  outputs of the interfaces are used to determine the polarity of the Tip and Ring pair which the C.O. uses for signalling during the active (off-hook) state of the interface. When the loop is closed by the interface, the trunk is in the normal or unreversed state. Some C.O.'s may reverse the polarity of Tip and Ring, to indicate the talking state. The interface will detect this condition and  $\overline{RC}$  will output a low level.

### External Circuitry Requirements

The loop seize circuit is completed with the addition of external components Q1, C5, R5 and K1.

K1, a DPST reed relay, is activated by relay control signal RC1. When the loop seizure is required, K1 is closed and the interface applies active termination across Tip and Ring. The relay should have a 0.5 amp contact capability and 12 VDC operation with a typical 500 $\Omega$  coil resistance. To prevent back EMF from damaging the relay drive transistor, (caused by the collapsing field of the inductive coil of the relay) a snubbing diode is provided on the hybrid and therefore not required externally. C5 and R5 provide relay contact noise filtering and transient noise suppression necessary for clamping inductive spikes created when the loop is closed during line seizure or dial pulsing.

Q1 provides current drive for the active termination, controlling the loop current flow of the current modulator circuitry. Selection of a suitable transistor for Q1 is made based on worst case conditions which include fault conditions. A 350 volt, or higher, rating for Q1 is necessary to meet high voltage requirements. The Tip and Ring input protection varistors limit any high voltage spikes to approximately 300 volts. Under worst case conditions Q1 must be able to handle close to 100mA of collector current and dissipate two watts continuously. During pulse dialling, current spikes are generated due to the inductive nature of the loop. A 0.5 amp continuous connector current rating is therefore recommended to provide a safe margin.

K2, R1 and R2 are required only for Ground Start applications. K2 is the same type of relay as K1 and is activated by RC2. Once again the snubbing diode is provided on the hybrid. R1 and R2 provide the -48V biasing the signalling (on-hook) state.

R6 and C6 constitute the Dummy Ringer required for the LS/GS trunk. These components are also part of the 600 $\Omega$  input impedance.

Protection circuitry on the Tip and Ring inputs may be required depending upon the trunk interface application. For maximum protection it is recommended to place fuses in series with the Tip

and Ring inputs of the interface, following by metal oxide varistors from Tip and Ground, Ring to Ground and Tip to Ring.

### Components List (for Figure 3)

R1*, R2*	= 30.9k $\Omega$ , $\pm$ 1% $\frac{1}{4}$ W
R4	= Transmit Gain Adjust Resistor = 301.5 E3x Gain $\frac{VX}{VTR}$ - 100 E3
	Typical Value = 200k $\Omega$ , $\pm$ 1% $\frac{1}{4}$ W
R3	= Receive Gain Adjust Resistor = 523.2 E3 x Gain $\frac{VTR}{VR}$
	Typical Value = 505k $\Omega$ , $\pm$ 1%, $\frac{1}{4}$ W
R5	= 510 $\Omega$ , $\pm$ 5%, $\frac{1}{4}$ W
R6	= 10k $\Omega$ , $\pm$ 5%, $\frac{1}{4}$ W
C1, C2, C3, C4	= 0.22 $\mu$ F, $\pm$ 10%, 200V
C5	= 0.1 $\mu$ F, $\pm$ 5%, 250V
C6	= 1.0 $\mu$ F, $\pm$ 5%, 250V
Q1	= 2N5657, NPN 350V, 0.5A, 20W
K1, K2	= 2A Reed Relay, E/M 12V 2 Form C Dip

\*Note: required for Ground Start applications, not required for Loop start applications.

**Absolute Maximum Ratings\***

	Parameter	Sym	Min	Max	Units
1	DC Supply Voltage	$V_{DD} - GNDD$	-0.3	+6.0	V
		$V_{EE} - GNDD$	-0.6	+0.3	V
		$V_{CC+} - GNDA$		+18.0	V
		$V_{CC} - GNDA$	+18.0		V
2	Storage Temperature	$T_{STG}$	-55	+125	°C

\* Exceeding these values may cause permanent damage. Functional operation under these conditions is not implied.

**Recommended Operating Conditions**

	Parameter	Sym	Typ*	Min	Max	Units	Comments
1	Operating Supply Voltage	$V_{DD}$	4.75	5.0	5.25	V	
		$V_{EE}$	-5.25	-5.0	-4.75	V	
		$V_{CC+}$	11.4	12.0	12.6	V	
		$V_{CC}$	-11.4	12.0	-12.6	V	
		$V_{Bat}$		-48		V	
2	Operating Current	$I_{DD}$			6.0	mA	RINGND high
		$I_{DD}$			-6.0	mA	
		$I_{DD}$			8.0	mA	
		$I_{DD}$			-8.0	mA	
3	Power Consumption	$P_C$			265	mW	
4	Operating Temperature	$T_{OP}$	0		70	°C	

\* Typical figures are at 25°C with nominal  $\pm 5V$  supplies for design aid only.

**DC Electrical Characteristics<sup>‡</sup>**

	Characteristics	Sym	Min	Typ*	Max	Units	Test Conditions
1	Input High Voltage RC1, RC2 RINGND	$V_{IH}$	2.7			V	
			4.5			V	
2	Input High Current RC1, RC2 RINGND	$I_{IH}$	2.5		5.0	mA	
					-100	$\mu A$	
3	Input Low Voltage RC1, RC2 RINGND	$V_{IL}$			0.7	V	
4	Input Low Current RC1, RC2 RINGND	$I_{IL}$			1.0	$\mu A$	
					1.1	mA	

<sup>‡</sup> DC Electrical Characteristics are over recommended operating conditions unless otherwise stated.

\* Typical figures are at 25°C with nominal  $\pm 5V$  supplies and are for design aid only.

**Control Inputs State Table**

	Parameter	Active	Idle
1	RC1	Logic high	Logic Low
2	RC2	Logic High	Logic Low
3	RINGND	Logic Low	Logic High
4	NETBAL AT&T compromise network (350 $\Omega$ + 1k $\Omega$ /0.2 $\mu F$ ) 600 $\Omega$ network	AGND  Open (no connection)	

## AC Electrical Characteristics

	Characteristics	Sym	Min	Typ*	Max	Units	Test Conditions
1	Ringling Voltage	VR	40	90	130	V <sub>rms</sub>	
2	Ringling Frequency			20		Hz	Voltage range 40 -120Vrms
	-1 version						
	-2 version			50		Hz	Voltage range 35 -120Vrms
3	Operating Loop Current	IL	18		70	mA	
4	Off-Hook DC Resistance	RT			300	Ω	@18mA
5	Operating Loop Resistance	RL			2300	Ω	@18mA
6	On-Hook Leakage Current			3		μA	RINGND = 5.0Vdc
7	Ring Ground Sink Current	IRG			100	mA	-48VDC with 200Ω in series on Ring lead
8	Tip and Ring AC Impedance			600		Ω	with 1.0kΩ + 1.0μF in parallel with Tip and Ring
9	Longitudinal Balance						
	metallic to longitudinal		60			dB	200-1000Hz
			40			dB	1000-4000Hz
	longitudinal to metallic		58			dB	200-1020Hz
			53			dB	1020-3020Hz
10	Return Loss Trunk to Line		20			dB	200-500Hz
			26			dB	500-1000Hz
			30			dB	1000-340Hz
11	Transhybrid Loss (single frequency) into 600Ω	THL		18.5		dB	200Hz
				34		dB	1000Hz
				30		dB	3000Hz
12	Transhybrid Loss (single frequency) into AT&T Compromise	THL		18		dB	200-1000Hz
				20		dB	1000-4000Hz
13	Frequency response (Output relative to 1kHz, VTR/VR and VX/VTR)		-0.15		0.05	dB	200Hz
			-0.10		0.05	dB	300Hz
			-0.10		0.05	dB	3000Hz
			-0.15		0.05	dB	3400Hz
							See Note 1
14	Idle channel noise			8		dBrnc	C-Message
15	Power Supply rejection ratio	PSR R		40		dB	
16	Analog signal overload level (adjustable gain)				6	dBm	1kHz, 0dBm = 0.775Vrms into 600Ω

\* Typical figure are at 25°C with nominal ±5V supplies and are for design aid only  
Note 1: Input 0dBm at VTR, or input 0.0775Vrms at VR. TR=600Ω Termination.

## DC Electrical Characteristics

	Characteristics	Sym	Min	Typ*	Max	Units	Test Conditions
1	Output High Voltage (TG, RC, RV, FC, RG)			4.75		V	No Load on output
2	Output High Current (TG, RC, RV, FC, RG)			0.17		mA	V <sub>OH</sub> =-2.7Vdc
3	Output Low Voltage (TG, RC, RV, FC, RG)			-0.30		V	No Load on output
4	Output Low Sink Current (TG, RC, RV, FC, RG)			-0.40		mA	V <sub>OL</sub> =-0.4Vdc

\* Typical figure are at 25°C with nominal ±5V supplies and are for design aid only

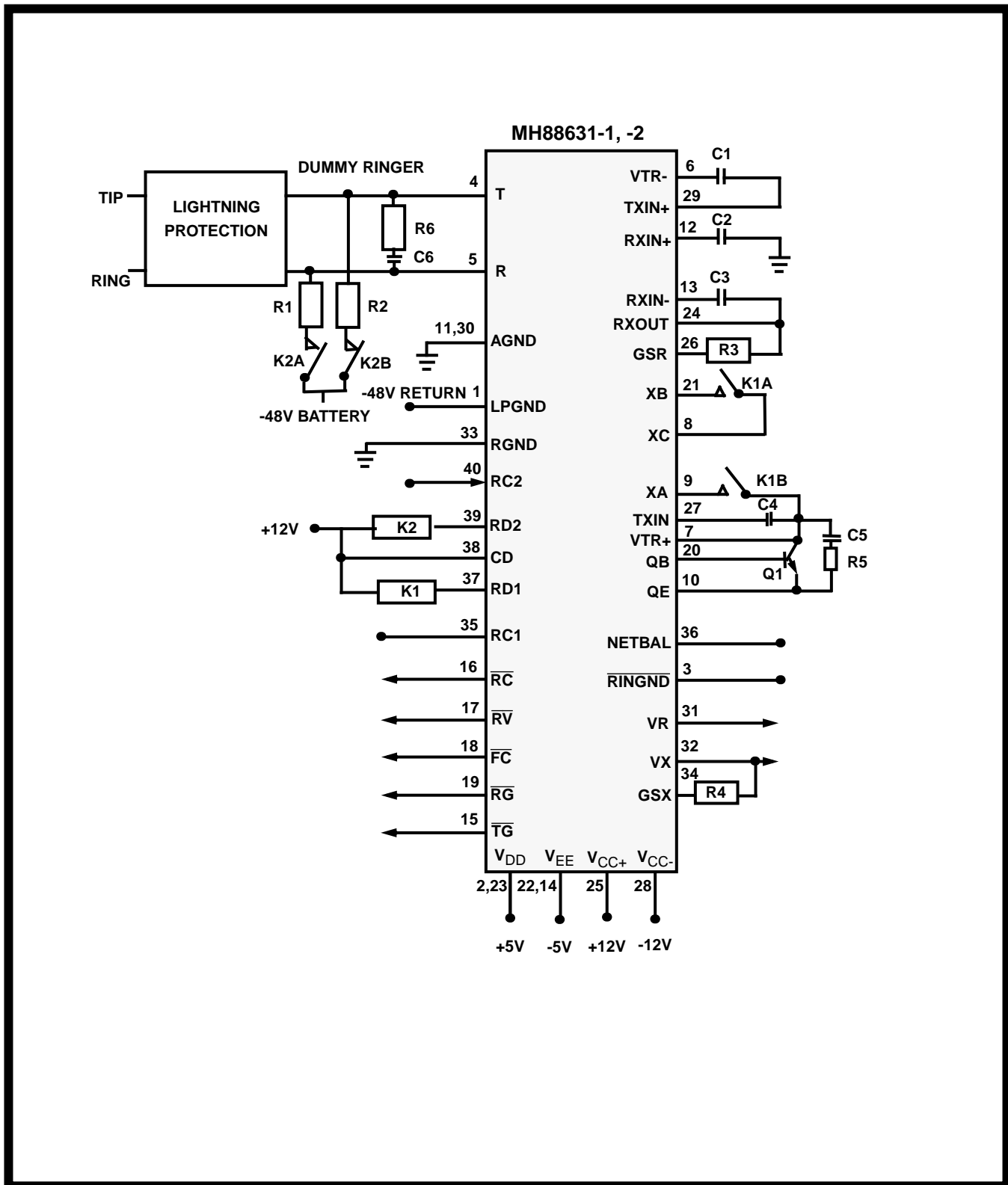

Figure 3 - Application Circuit



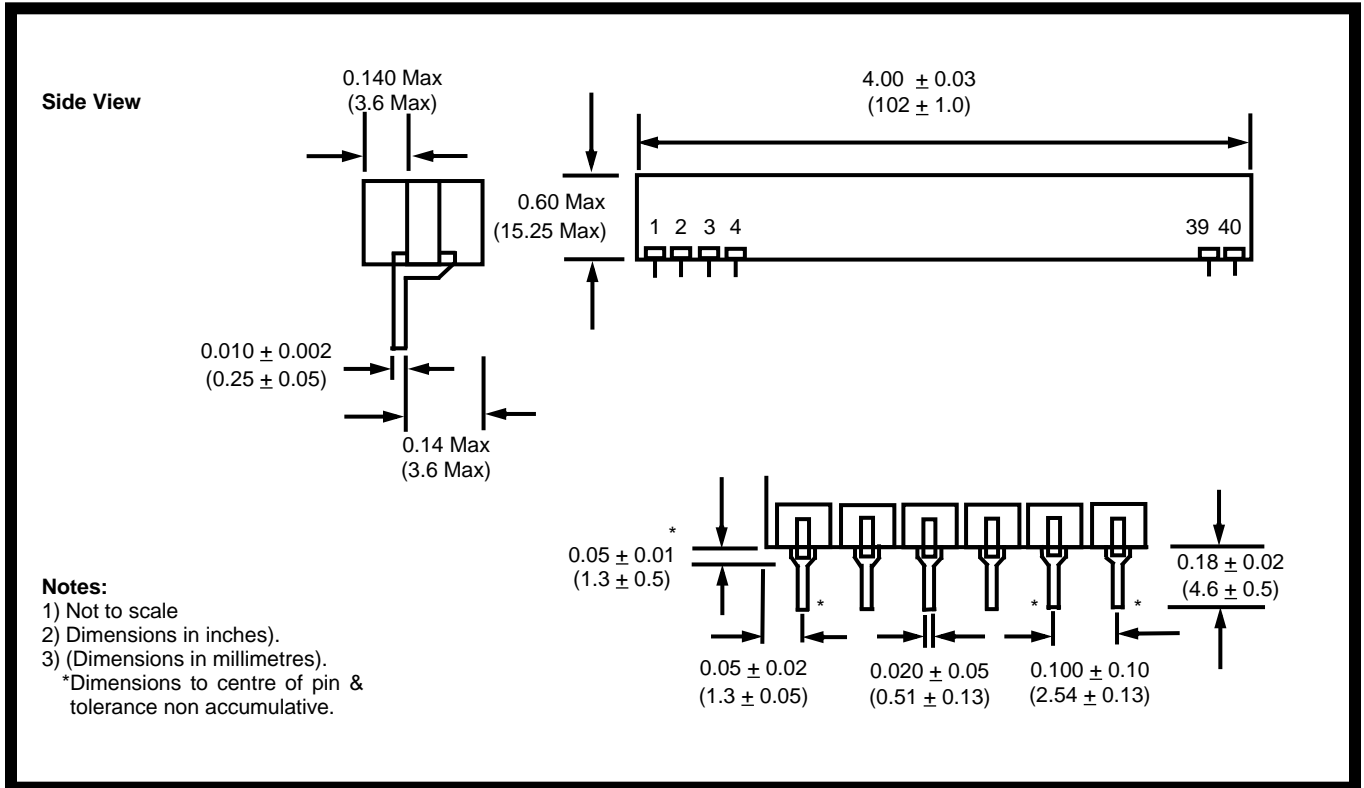

Figure 4 - Mechanical Data

Notes: